

Function

All electromagnetic flowmeters are based on Faraday's law of induction:

$$U_M = B \cdot v \cdot d \cdot k$$

U_M = Measured voltage induced in the medium perpendicular to the magnetic field and the flow direction. The voltage is tapped at two point electrodes.

B = Magnetic flux density which permeates the flowing medium perpendicular to the flow direction.

v = flow velocity of medium

d = internal diameter of metering tube

k = proportionality factor or sensor constant

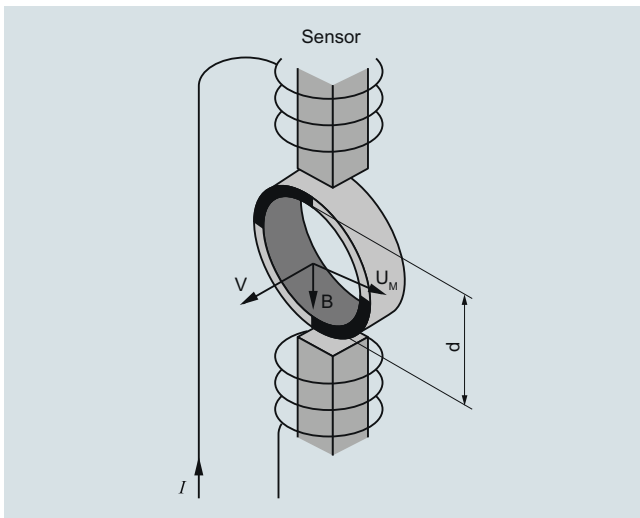

Function and measuring principle of electromagnetic measurement

An electromagnetic flowmeter generally consists of a magnetically non-conducting metering tube with an internal electrically non-conducting surface, magnet coils connected in series and mounted diametrically on the tube, and at least two electrodes which are inserted through the pipe wall and are in contact with the measured medium. The magnet field coils through which the current passes generate a pulsed electromagnetic field with the magnetic flux density B perpendicular to the pipe axis.

This magnetic field penetrates the magnetically non-conducting metering tube and the medium flowing through it, which must have a minimum electrical conductivity.

According to Faraday's law of induction, a voltage U_M is generated in an electrically conducting medium, and is proportional to the flow velocity v of the medium, the magnetic flux density B , and the distance between the electrodes d (internal diameter of pipe).

The signal voltage U_M is tapped by the electrodes which are in contact with the medium, and passed through the insulating pipe wall. The signal voltage U_M which is proportional to the flow velocity is converted by an associated transmitter into appropriate standard signals such as 4 to 20 mA.

SITRANS F M diagnostics

The diagnostic functions are all internal tools in the meter:

- Identification in clear text and error log
- Error categories: function; warning; permanent and fatal errors
- Transmitter self-check including all outputs and the accuracy
- Sensor check: coil and electrode circuit test
- Overflow
- Empty pipe: partial filling; low conductivity; electrode fouling

SITRANS F M Verificator (MAG 5000 and 6000)

The SITRANS F M Verificator is an external tool designed for MAG 5000 and MAG 6000 with MAG 1100, MAG 1100 F, MAG 3100, MAG 3100 P or MAG 5100 W sensors to verify the entire product, the installation and the application.

The goal is to improve operation, reduce downtime and maintain measurement accuracy as long as possible.

The SITRANS F M Verificator is highly advanced and carries out the complex verification and performance check of the entire flowmeter system, according to unique Siemens patented principles. The whole verification test is automated and easy to operate so there is no opportunity for human error or influence. The system is traceable to international standards and tested by WRc (Water Research Council).



SITRANS F M Verificator

- Stand alone Verificator to measure a number of selected parameters in the flow sensor and a transmitter which affects the integrity of the flow measurement
- Up to 20 measurements can be stored in the Verificator
- The Verificator can be connected via a serial cable to a PC enabling download of the data. A Windows program enables printing and management of vericator reports.

Verification - Steps

Verification of a SITRANS F M flowmeter consists of the following test routines:

1. Transmitter test
2. Flowmeter and cable insulation test
3. Sensor magnetism test

Flow Measurement

SITRANS F M

SITRANS F M Verificator

1. Transmitter test

The transmitter test is the traditional way of on-site testing on the market and checks the complete electronic system from signal input to output.

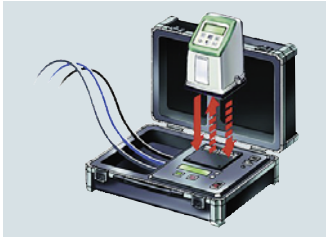

Transmitter test

Using the excitation power output, which is generated to drive the magnetic field of the sensor, the verificator simulates flow signal to the transmitter input. By measuring the transmitter outputs the verificator calculates its accuracy against defined values. Test includes:

- Excitation power to drive the magnetic field
- Signal function from signal input to output
- Signal processing – gain, offset and linearity
- Test of analogue and frequency output

2. Insulation test

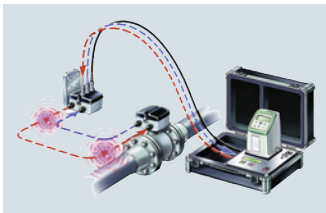

Flowmeter insulation test

The verification test of the flowmeter insulation is a „cross talk“ test of the entire flowmeter which ensures that the flow signal generated in the sensor is not affected by any external influences.

In the "cross-talk" test the verificator generates a high voltage disturbance within the coil circuit and then looks for any "cross-talk" induced in the flow signal circuit. By generating dynamic disturbances close-coupled to the flow signal, the flowmeter is tested for noise immunity to a maximum level:

- EMC influence on the flow signal
- Moisture in sensor, connection and terminal box
- Non-conductive deposit coating the electrodes within the sensor
- Missing or poor grounding, shielding and cable connection.

3. Sensor magnetism test

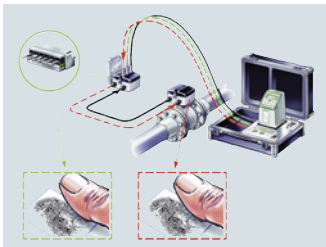

Sensor magnetism test

The verification of the sensor magnetism is a "boost" test of the magnetic field coil. The test ensures that the magnetism behaviour is like the first time, by comparing the current sensor magnetism with the "fingerprint" which was determined during initial calibration and stored in the SENSORPROM memory unit. In the "boost" test the verificator changes the magnetic field in certain pattern and with high voltage to get quick stable magnetic condition. This unique test is fulfilled without any interference or compensation of surrounding temperature or interconnecting cabling.

- Changes in dynamic magnetic behaviour
- Magnetic influence inside and outside the sensor
- Missing or poor coil wire and cable connection

Certificate

The test certificate generated by a PC contains:

- Test result with passed or failed
- Installation specification
- Flowmeter specification and configuration
- Verificator specification with date of calibration ensuring traceability to international standards.

MAGFLO® Verification Certificate						
Customer:			MAGFLO® Identification:			
Name			TAG No./Name	0		
Address			Sensor Code No.	7ME634		
			Sensor Serial No.	057701H142		
			Transmitter Code No.	7ME692		
Phone			Transmitter Serial No.	109418N080		
Email			Location			
Results:						
Verification file name or No.			FT-103FT2801			
Transmitter			Passed			
Sensor			Insulation Passed			
			Magnetic Circuit Passed			
Velocity		Current Output		Frequency Output		
Theoretical	Theoretical	Actual	Deviation	Theoretical	Actual	Deviation
0.5m/s	4.800mA	4.802mA	0.25%	0.500kHz	0.501kHz	0.11%
1.0m/s	5.600mA	5.601mA	0.08%	1.000kHz	1.001kHz	0.07%
3.0m/s	8.800mA	8.804mA	0.08%	3.000kHz	3.004kHz	0.14%
Current Output 4-20mA			Frequency Output 0-10kHz			
Transmitter Settings:			Sensor Details:			
Basic	Qmax.	2.00000 m ³ /h				
	Flow Direction	Positive				
	Low flow Cut-off	1.50%				
	Empty Pipe	ON				
Output	Current Output	ON (4-20mA)				
	Time Constant	5.0 Sec.				
	Relay Output	Error Level				
	Digital Output	Pulse				
	Frequency Range	N/A				
	Time Constant	N/A				
	Volume/pulse	1.0 l/p				
	Pulse width	0.51999998 sec.				
	Pulse polarity	Positiv				
Totalizer 1 value before test		819442.93213 l				
Totalizer 1 value after test		819458.92334 l				
Totalizer 2 value before test		693.87579 l				
Totalizer 2 value after test		693.88145 l				
Operating time in days		1068				
		Size		DN 15 1/2 IN		
		Cal. Factor		0.16531426		
		Correction Factor		1.0		
		Excitation Freq.		12.5Hz		
		Verificator Details (083F5060)				
		Serial No. 107920N490				
		Device No. 94683				
		Software Version 1.40				
		PC-Software Version 5.01				
		Cal. date 2015.10.26				
		ReCal. date 2016.10.26				
Comments						
These tests verify that the flowmeter is functioning within 2% deviation of the original test parameters.						
Verification is traceable to National and International Standards.						
Date and signature						
2016.10.26						

Description

SITRANS F M Verificator

- 11 ... 30 V DC, 11 ... 24 V AC, 115 ... 230 V, 50 Hz
- 11 ... 30 V DC, 11 ... 24 V AC, 115 ... 230 V, 60 Hz

Article No.

FDK:083F5060

FDK:083F5061

Note:

It is mandatory to have the Verificator returned to the factory once a year for check and re-verification.